

Arrive®

Portable Display & Workstation

exhibiting solutions



Display & Workstation in 1 Case! Arrive in Style with Ease

Single-Case Portability!

With Arrive, you get an entire display and functional workstation in one easy-to-manage case. In minutes, Arrive converts from protective case to stylish workstation. That means no cases to hide or store and no waiting for your cases after the show.



Arrive case fits an entire Exalt® or Myriad® inline banner stand display plus workstation conversion components (except digital screen).

Which banner stand display is right for you? Arrive works with:

Exalt® Curved Banner Stand

The classic curved look and the ease of a banner stand! Exalt can be used in a linear format or, with the simple flick of levers, Exalt converts from linear to curved.

Myriad® Multi-Functional Banner Stand

Myriad gives you a full inline display with just two lightweight banner stand units and a center fabric graphic panel. Myriad's built-in merchandising system combines the ability to display product or literature with the ease and convenience of a banner stand.



Skyline Exalt® and Myriad® banner stands with fabric graphics are a breeze to install.

Case to Workstation



Arrive® quickly transforms from a banner stand case into a functional workstation tailored to fit your brand and show objectives.



1 Accessory Pole

Digital screen, shelf or literature holder are easy to attach and add functionality.

2 Counter Top

Graphic or laminate surface is perfect for taking leads or displaying product.

3 Wire Management

Built-in wire management conceals cords for a clean look.

4 Internal Shelf

Easy access to water or other items. Holds up to 5 lbs. (2.3 kg).

5 Accessory Tray

Stores and protects 3 exhibit lights and multiple accessories!

6 Fabric Graphic Wrap

Match your display graphics for a cohesive brand presentation. Easy to install and change out when your message changes.

Arrive®



Digital Screen

Great for presentations or demonstrations. Arrive's built-in wire management conceals cords for a clean, professional look.



Literature Holder

Make your brochures or at-show promotions accessible with Arrive's literature holder.

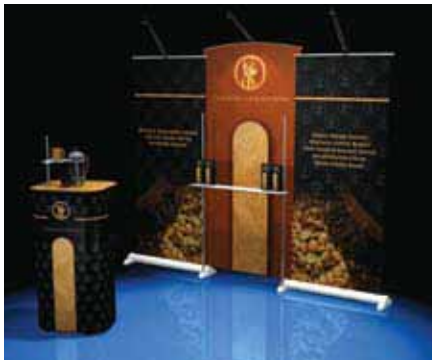

Product Display Shelf

Arrive's shelf is stylish and repositionable. The spanning shelf on Myriad also fits in the Arrive case with no extra cases required.

Specifications

Exalt® Inline Display Weight: 30.8 lbs. (14 kg)

Top View

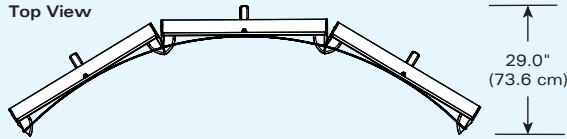

Front View

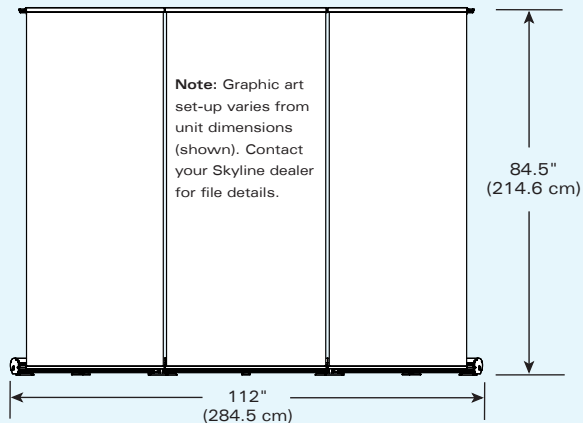

Arrive® Workstation

Weight: 37 lbs. (16.8 kg)

(Case closed)

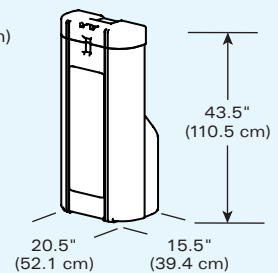

Myriad® Inline Display Weight: 26 lbs. (11.8 kg)

Top View

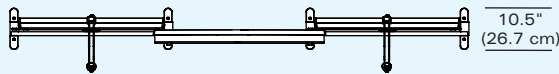

Front View

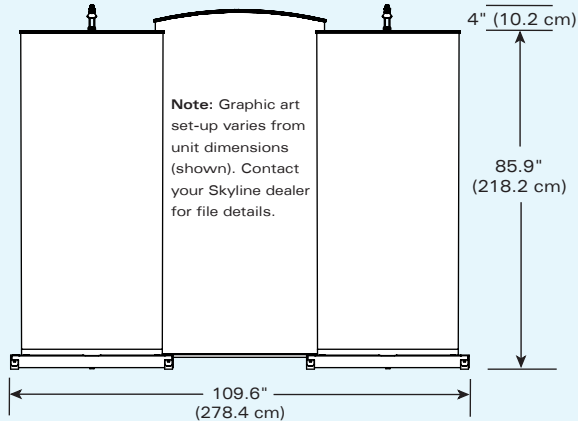

(Case converted)

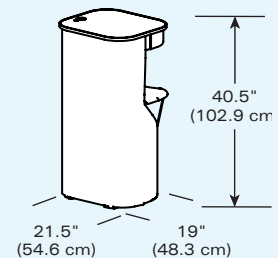

Arrive patent pending.

Skyline Displays

19 Morgan Street
Fortitude Valley Qld 4006

t +61 7 3252 4343
f +61 7 3252 4646

www.skyline.com.au